

Eine kommerzielle Nutzung ist ohne ausdrückliche Zustimmung des Copyright-Inhabers nicht gestattet!

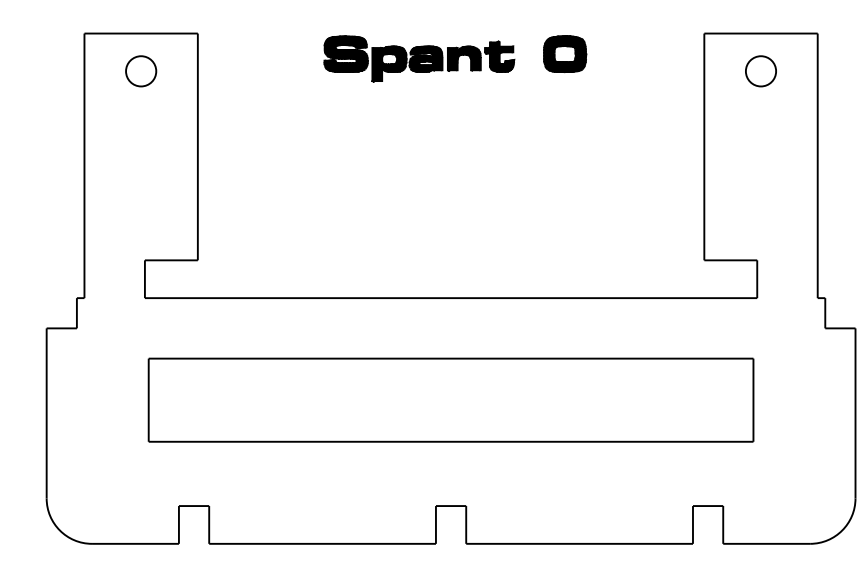

Spant 0

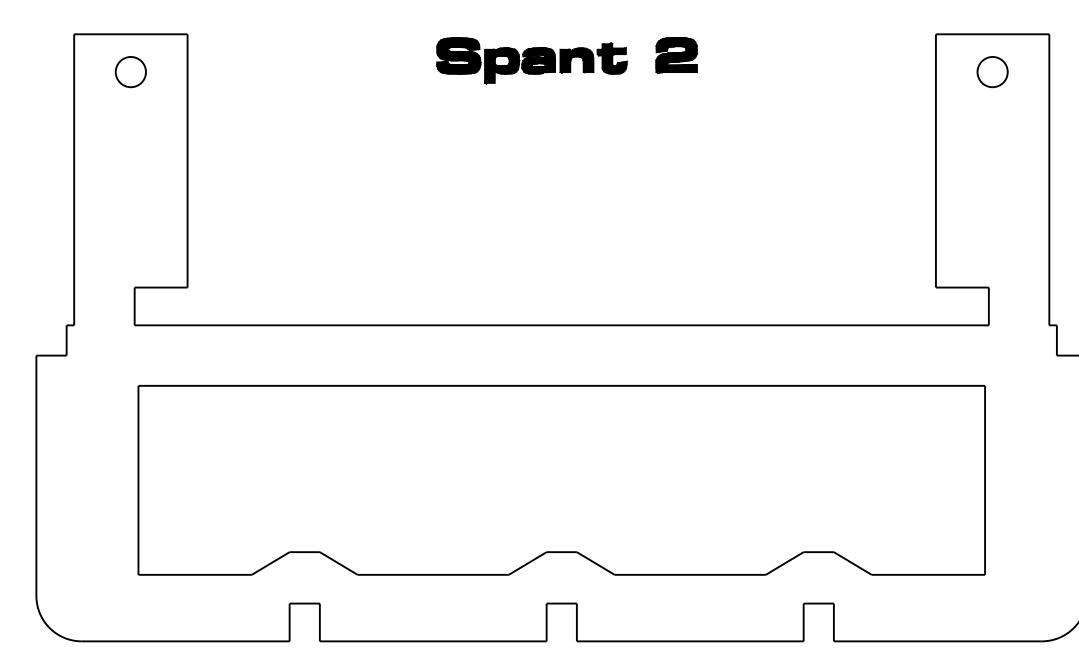

Spant 2

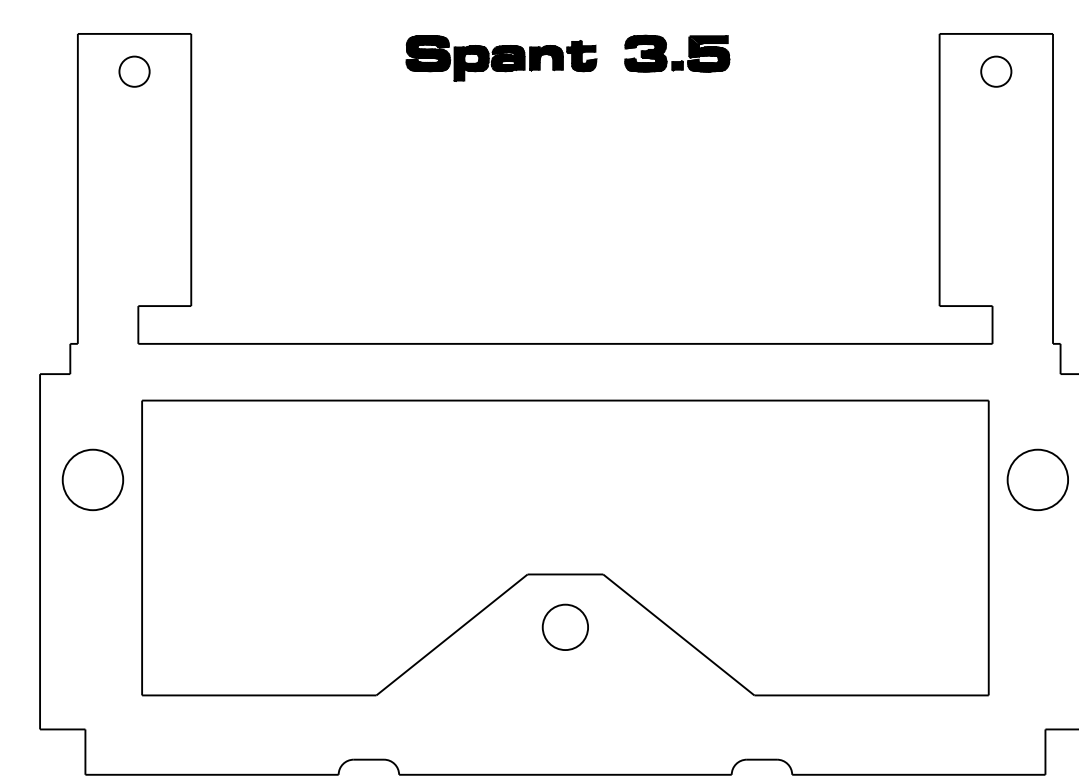

Spant 3.5

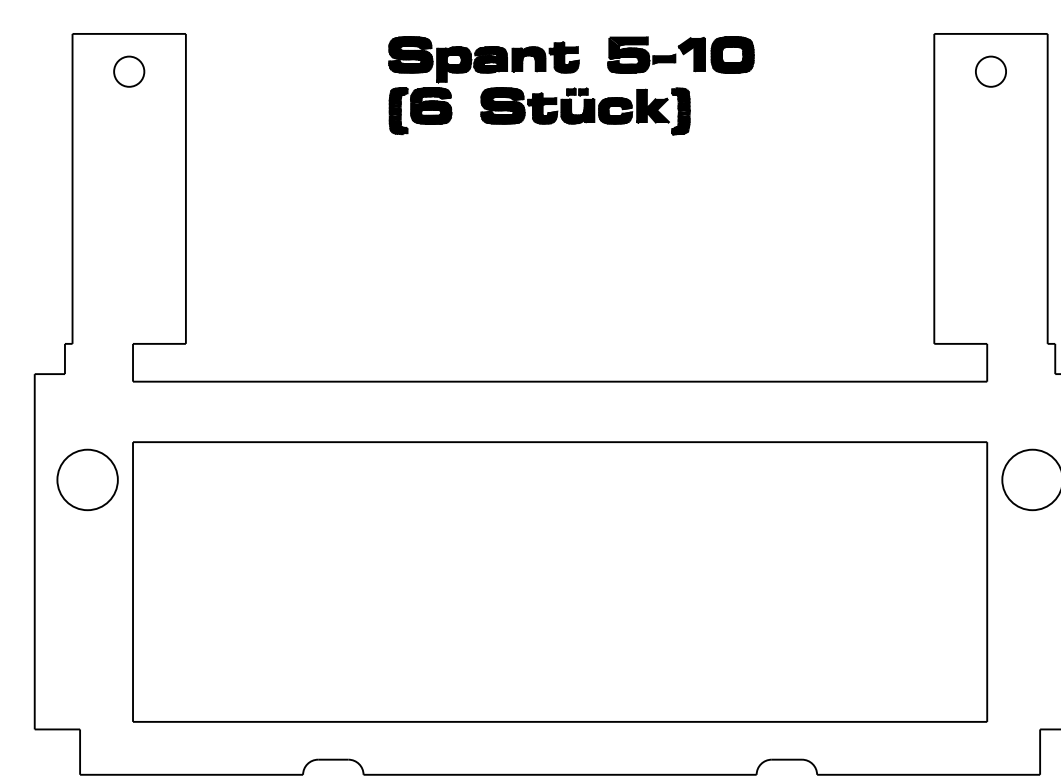

Spant 5-10
(6 Stück)

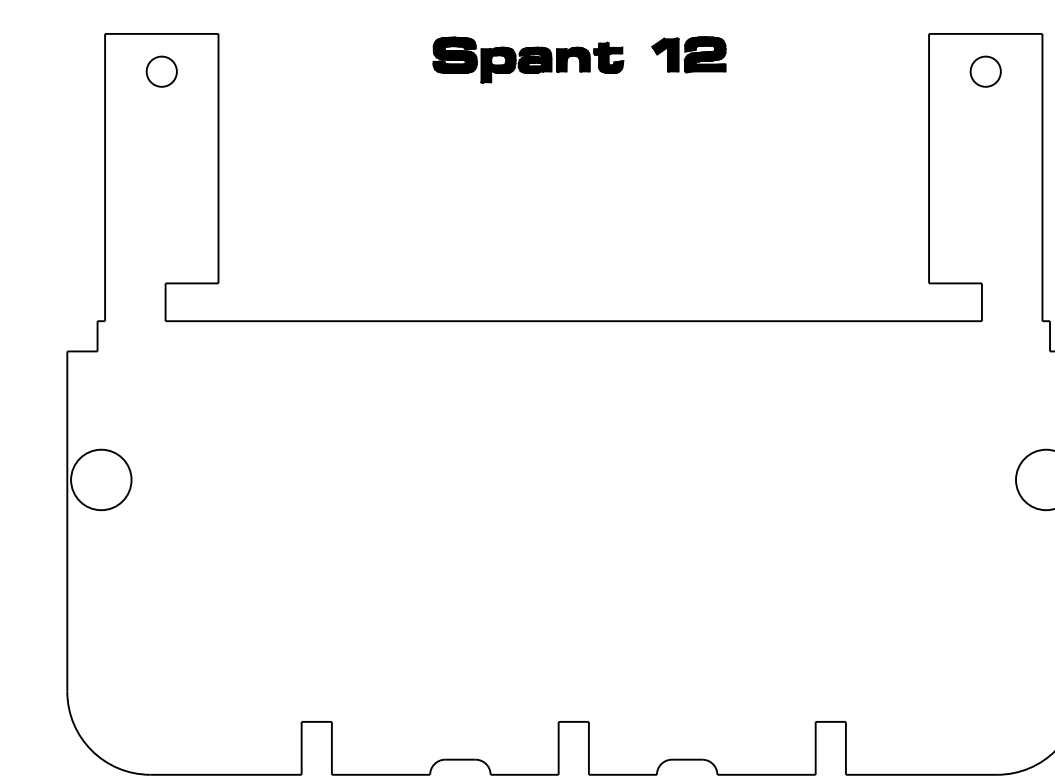

Spant 12

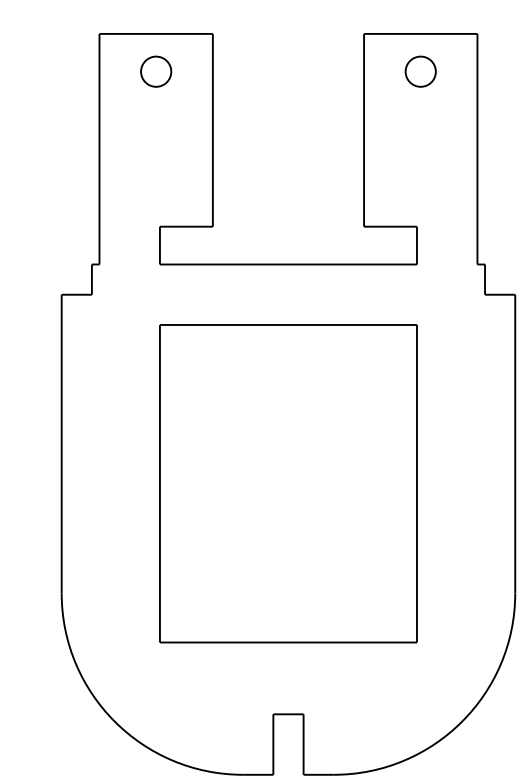

Spant 14

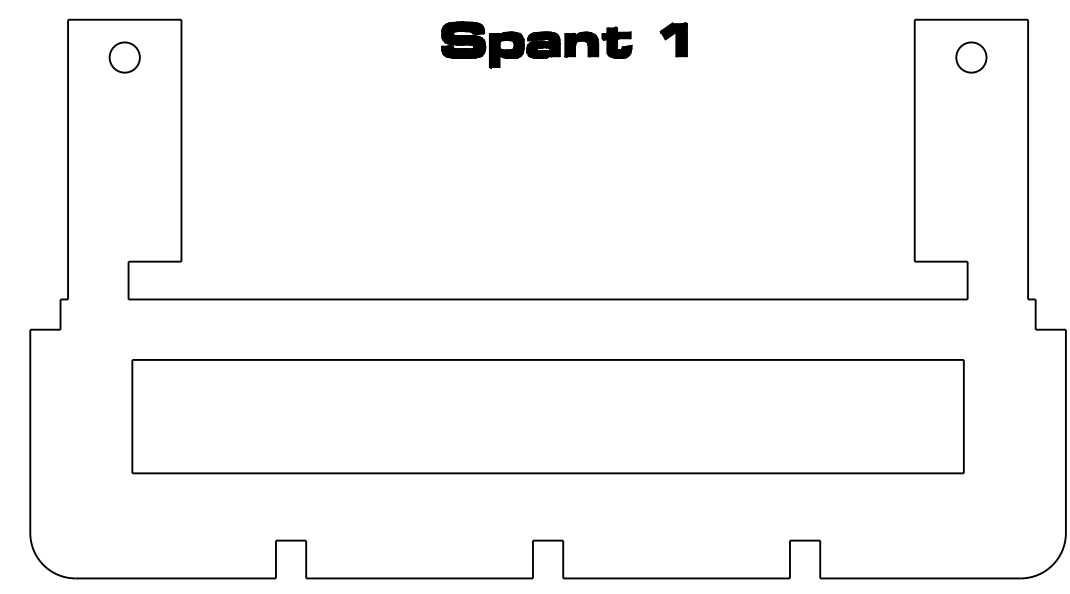

Spant 1

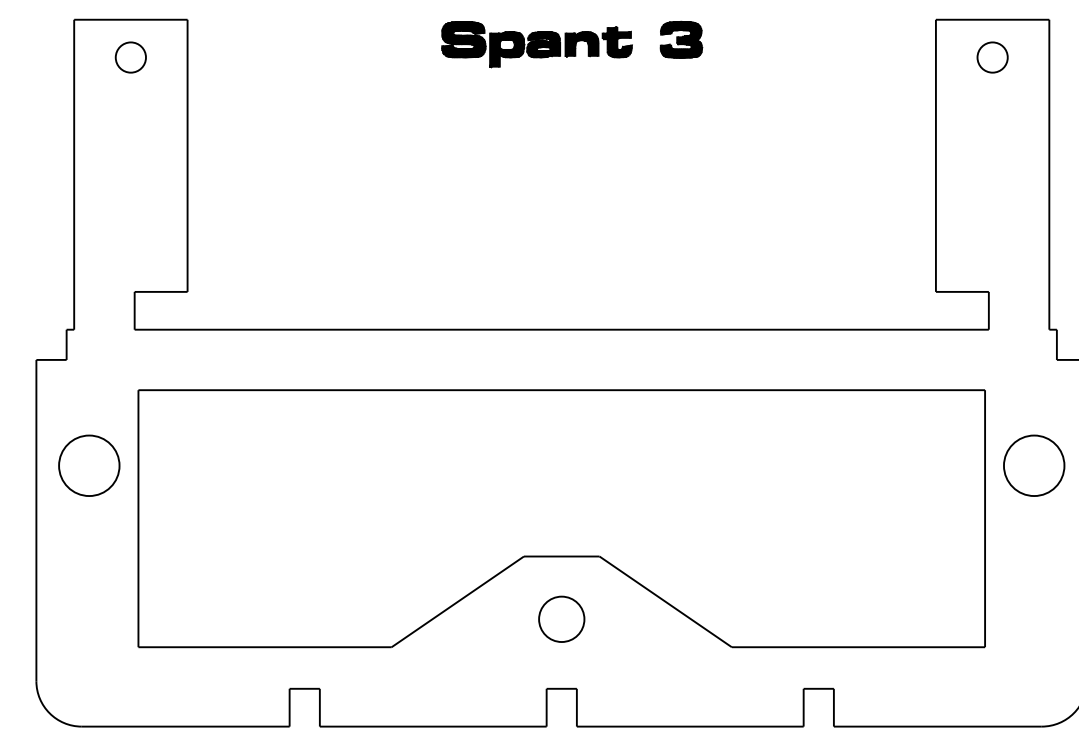

Spant 3

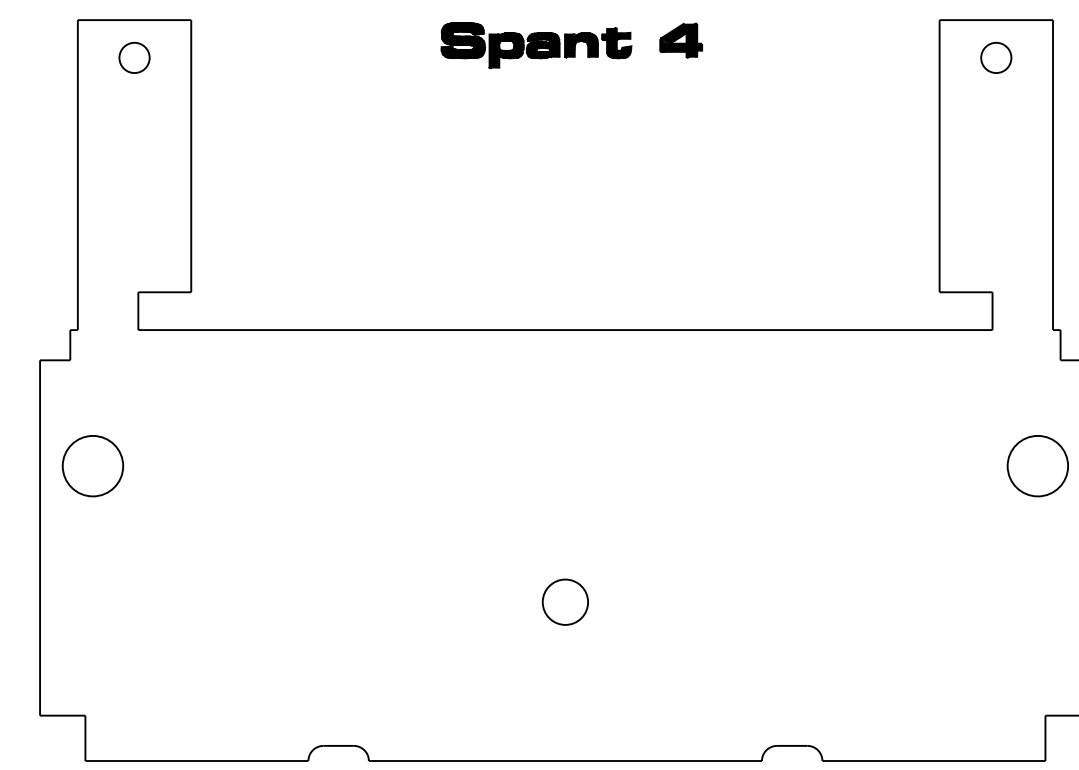

Spant 4

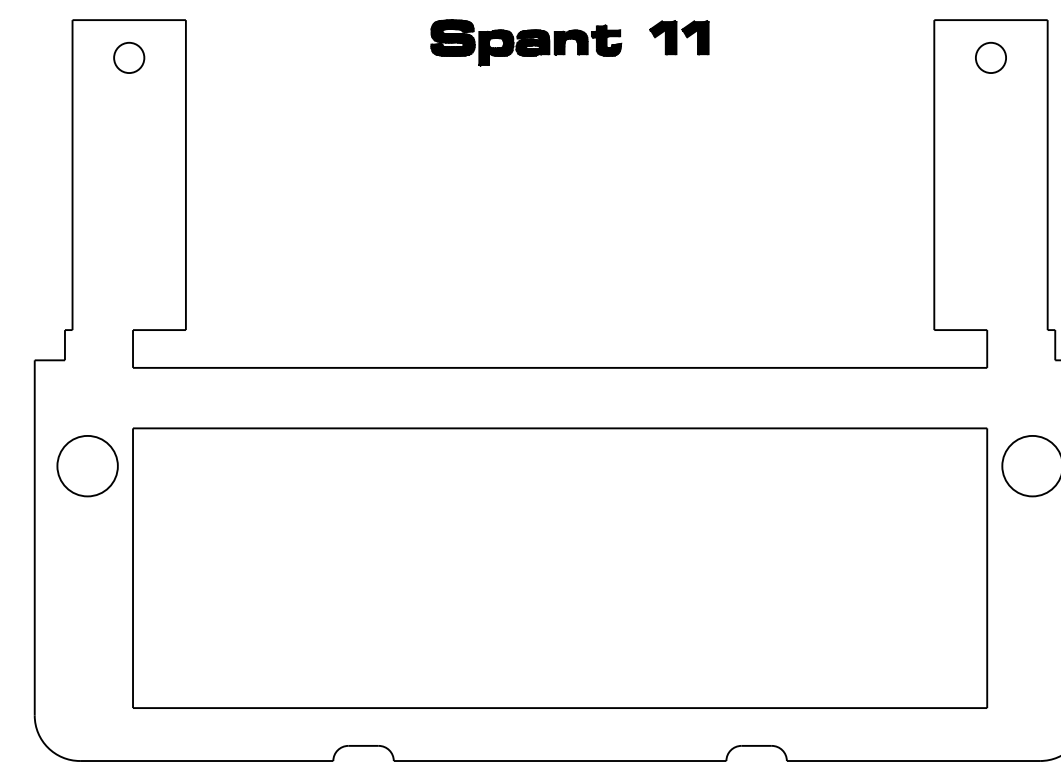

Spant 11

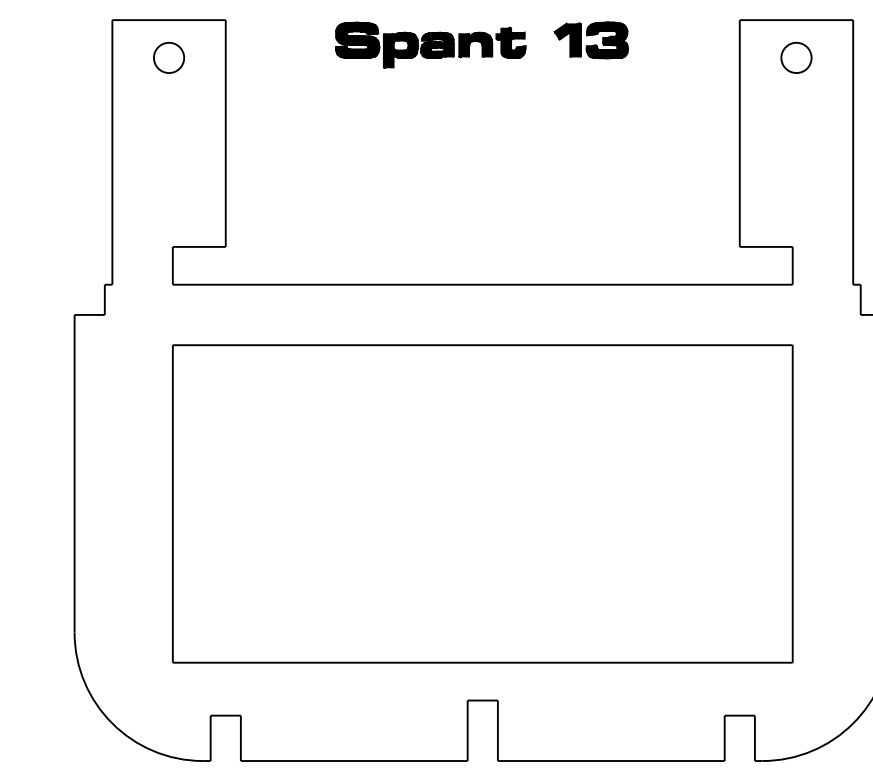

Spant 13

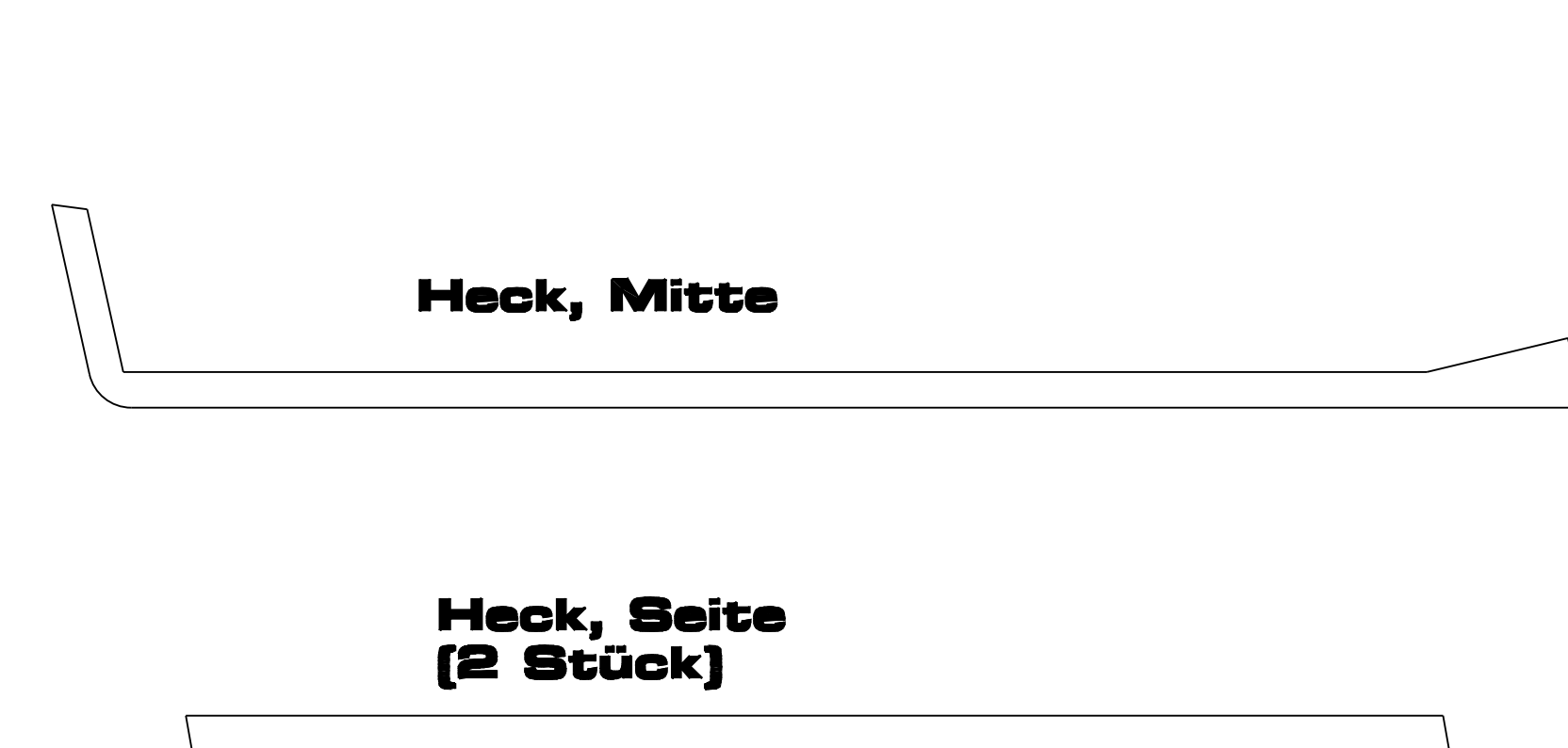
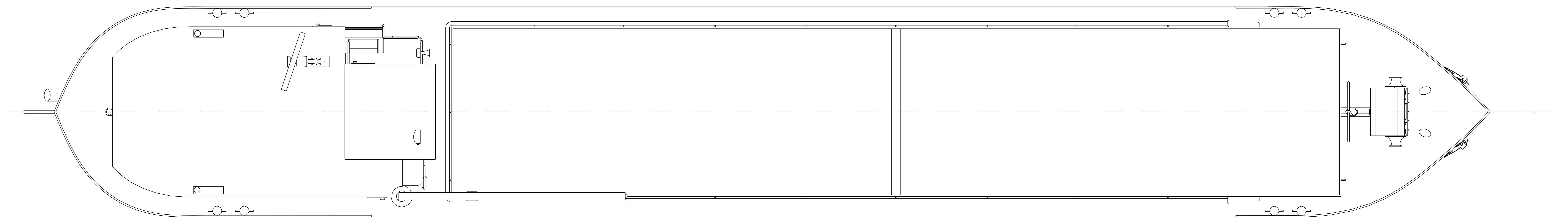
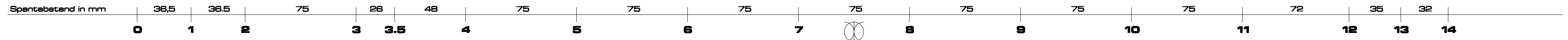

Heck, Mitte



Heck, Seite
[2 Stück]

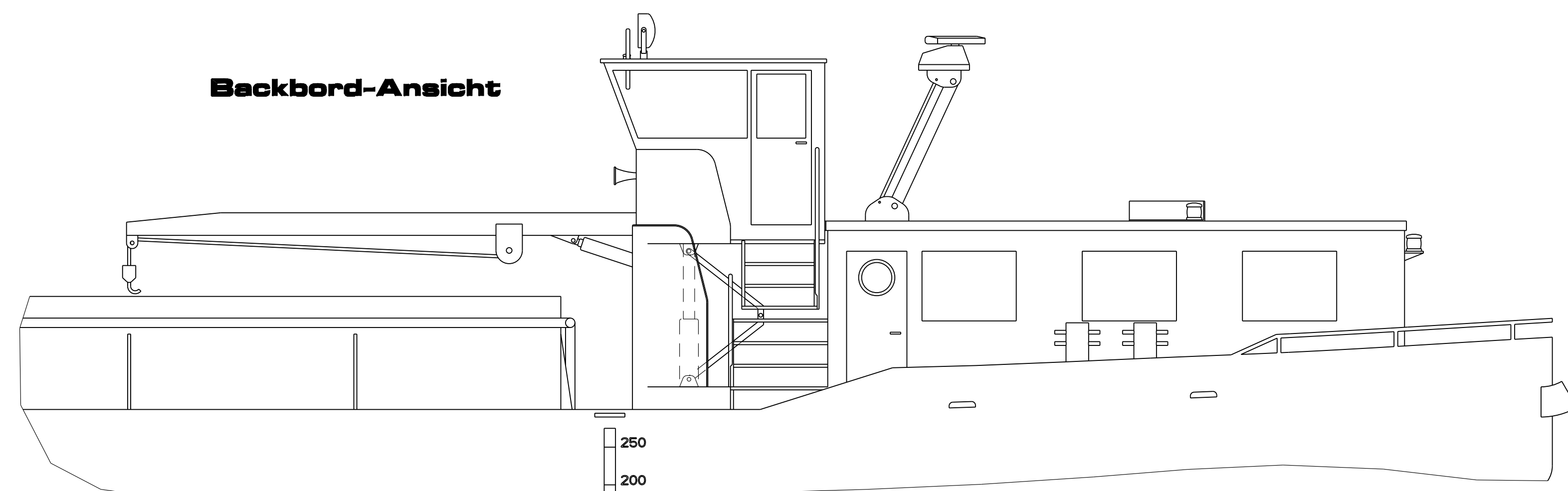

Beckbord-Ansicht

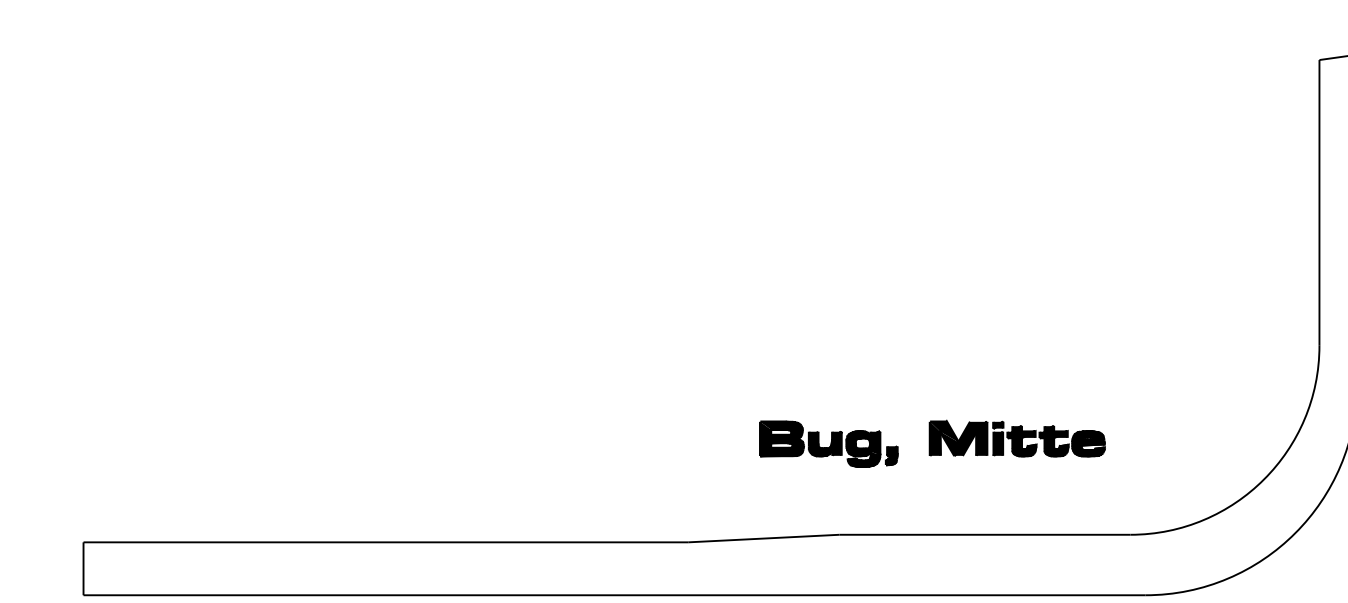

Bug, Mitte

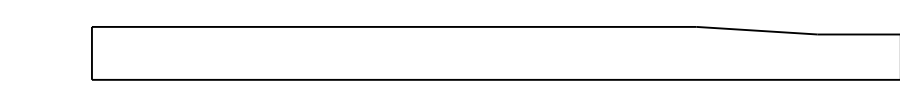

Bug, Seite
[2 Stück]

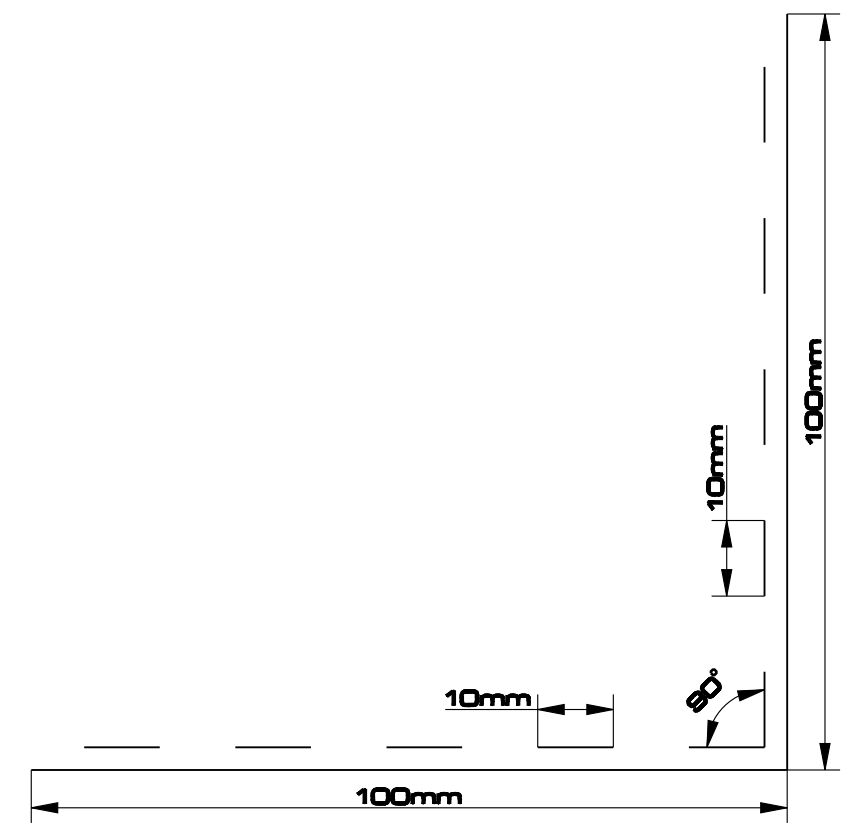

Binnenschiff Hermine
typisches Binnenschiff der 70er Jahre
Ausführung: Bulker (Schüttgutfrachter)
Maßstab: 1:50
Länge: 95,0cm
Breite: 14,0cm
Tiefgang [KWL]: 3,6cm
Copyright 2011, IG Ruhr-Piraten Schwerte (David Vehl)